



FENI POLYTECHNIC INSTITUTE, FENI



Teacher Information Name:Mintu das Jr.Instructor(Power)





FENI POLYTECHNIC INSTITUTE, FENI



Subject Name: Power Engineering Drawing

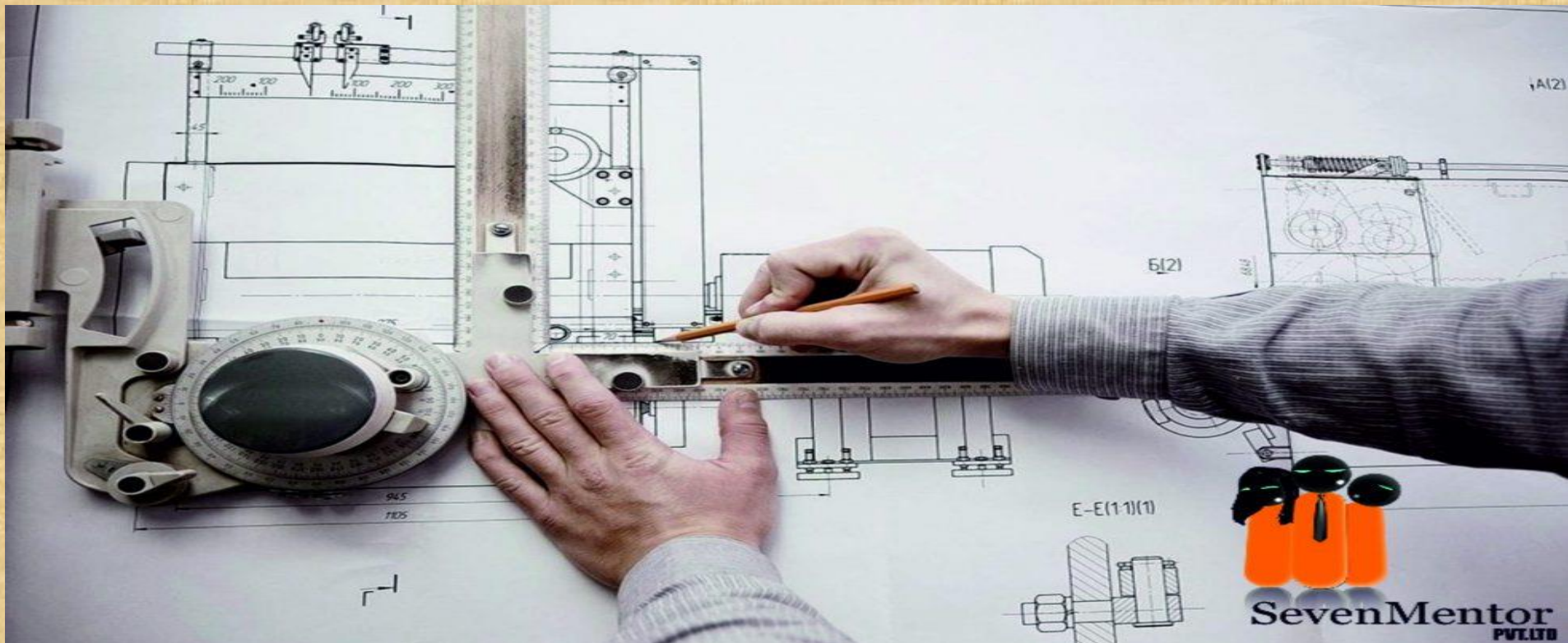



- **Reference Books:**

- 1. Technical Drawing – Frederick E. Giesecke, Alva Mitchell, Henry Cecil Spencer, Ivan Leroy Hill and John Thomas Dygdon.

- 2. Fundamental of Engineering Drawing – Warren J. Luzaddder and Jon M. Duff.

- **Drawing:** A drawing is a graphic representation of a real thing, an idea or a proposed design for construction later. Drawing may take many forms, but the graphic method of representation is a basic natural form of communication of ideas that is universal and timeless in character



FENI POLYTECHNIC INSTITUTE, FENI



Types of Drawing: Man has developed graphic representation along two distinct lines, according to his purpose: (i) Artistic and (ii) Technical. From the beginning of time, artists have used drawing to express aesthetic, philosophic or other abstract ideas. In ancient times nearly everybody was illiterate. There was no printing and hence no newspaper or books. People learned by listening to their superiors and by looking at pictures, or drawing in public places. Everybody could understand picture and they were a principle source of information. The other line along which drawing has developed has been the technical. From the beginning of recorded history, man has used drawing to represent his design of objects to be built or constructed



FENI POLYTECHNIC INSTITUTE, FENI



- **Instruments:** A complete list of equipments, which should provide a satisfactory selection for students of technical drawing is as follows:
- (1) Drawing board (Approximate 20"×20"), drafting table or desk.
- (2) T-square (24", transparent edge)
- (3) Set of instruments
- (4) 45° triangle (8" side)
- (5) 30° ×60° triangle (10" long side)
- (6) Irregular curve
- (7) Pencils (2B, HB, 3H)
- (8) Protractor
- (9) Eraser
- (10) Dusting brush
- (11) Drafting tape
- (12) Circle and ellipse templates.



FENI POLYTECHNIC INSTITUTE, FENI



- **READING DRAWINGS** To read a drawing, you must know how engineers use lines, dimensions, and notes to communicate their ideas on paper. In this section, we briefly discuss each of these drawing elements. **Lines**
- Figure 3-38 figure 3-38. shows many of the different types of lines that are used in drawings. You can see that each line has a specific meaning you must understand to interpret a drawing correctly. Let's discuss a few of the most important types. A **visible line** (sometimes called object line) is used to show the edges of an object that are visible to the viewer. For example, if you look at one of the walls of the room you are in, you can see the outline of the walls and (depending on the wall you are looking at) the outline of doors and windows. On a drawing, these visible outlines or edges can be shown using visible lines that are drawn as described in



FENI POLYTECHNIC INSTITUTE, FENI



- Now look at the wall again. Assuming that the wall is wood frame, you know that there are studs or framing members inside the wall that you cannot see. Also, the wall may contain other items, such as water pipes and electrical conduit, that you also cannot see. On a drawing, the edges of those concealed studs and other items can be shown using fig.3-38). These lines are commonly used in drawings. As you can imagine, the more hidden lines there are, the more difficult it becomes to decipher what is what; however, there is another way these studs and other items can be “seen.” Imagine that you “cut away” the wallboard that covers the wall and replace it with a sheet of clear plastic. That clear plastic can be thought of as a fig.3-38) through which the previously concealed studs, piping, and conduit are now visible. Now those items can be drawn using visible lines, rather than hidden lines. A view of this type is called a sectional view, and a drawing of the view is called a **hidden lines (cutting or viewing plane (section drawing)**. Section drawings are commonly used to show the internal components of a complicated object



FENI POLYTECHNIC INSTITUTE, FENI



LINE STANDARDS							
NAME	CONVENTION	DESCRIPTION AND APPLICATION	EXAMPLE	NAME	CONVENTION	DESCRIPTION AND APPLICATION	EXAMPLE
VISIBLE LINES		HEAVY UNBROKEN LINES USED TO INDICATE VISIBLE EDGES OF AN OBJECT		LEADER		THIN LINE TERMINATED WITH ARROW-HEAD OR DOT AT ONE END USED TO INDICATE A PART, DIMENSION OR OTHER REFERENCE	
HIDDEN LINES		MEDIUM LINES WITH SHORT EVENLY SPACED DASHES USED TO INDICATE CONCEALED EDGES		PHANTOM OR DATUM LINE		MEDIUM SERIES OF ONE LONG DASH AND TWO SHORT DASHES EVENLY SPACED ENDING WITH LONG DASH USED TO INDICATE ALTERNATE POSITION OF PARTS, REPEATED DETAIL OR TO INDICATE A DATUM PLANE	
CENTER LINES		THIN LINES MADE UP OF LONG AND SHORT DASHES ALTERNATELY SPACED AND CONSISTENT IN LENGTH USED TO INDICATE SYMMETRY ABOUT AN AXIS AND LOCATION OF CENTERS		STITCH LINE		MEDIUM LINE OF SHORT DASHES EVENLY SPACED AND LABELED USED TO INDICATE STITCHING OR SEWING	
DIMENSION LINES		THIN LINES TERMINATED WITH ARROW HEADS AT EACH END USED TO INDICATE DISTANCE MEASURED		BREAK (LONG)		THIN SOLID RULED LINES WITH FREEHAND ZIG-ZAGS USED TO REDUCE SIZE OF DRAWING REQUIRED TO DELINEATE OBJECT AND REDUCE DETAIL	
EXTENSION LINES		THIN UNBROKEN LINES USED TO INDICATE EXTENT OF DIMENSIONS		BREAK (SHORT)		THICK SOLID FREE HAND LINES USED TO INDICATE A SHORT BREAK	
				CUTTING OR VIEWING PLANE		THICK SOLID LINES WITH ARROWHEAD TO INDICATE DIRECTION IN WHICH SECTION OR PLANE IS VIEWED OR TAKEN	
				VIEWING PLANE OPTIONAL			
				CUTTING PLANE FOR COMPLEX OR OFFSET VIEWS		THICK SHORT DASHES USED TO SHOW OFFSET WITH ARROW-HEADS TO SHOW DIRECTION VIEWED	

Figure 3-38. Line characters and uses.



FENI POLYTECHNIC INSTITUTE, FENI



- Many times, you will see lines drawn on the visible surfaces of a section drawing. These lines, called **section lines**, are used to show different types of materials. .Some of the types of section lines you are likely to encounter as a welder are shown in figure 3-39.

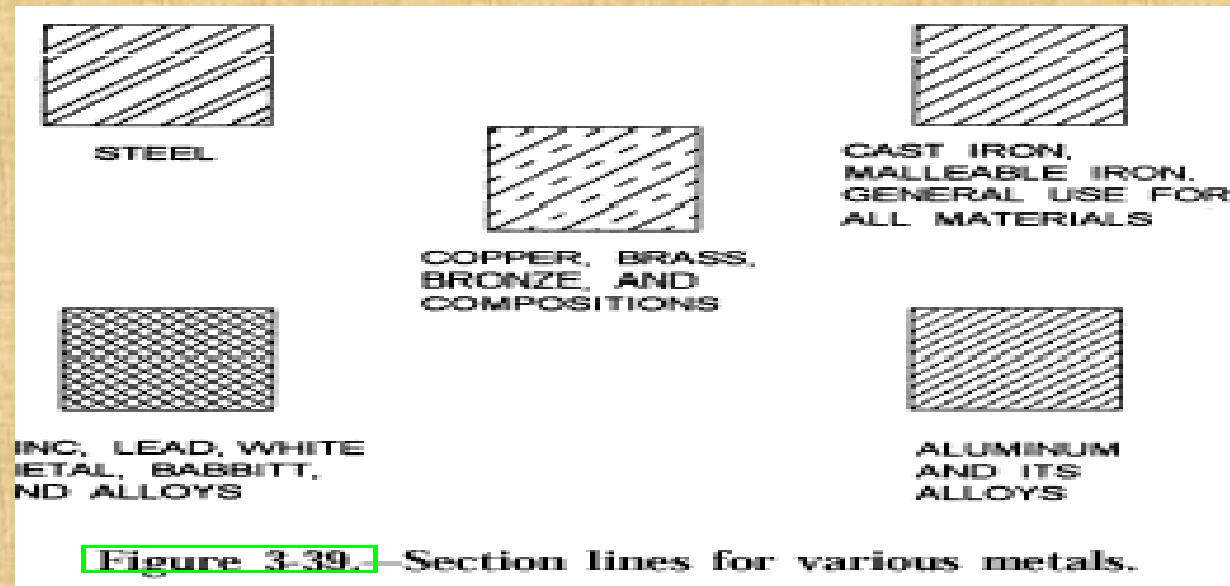



FENI POLYTECHNIC INSTITUTE, FENI



- **Dimensions** While engineers use lines to describe the shape or form of an object, they use dimensions to provide a complete size description. Dimensions used on drawings are of two types: size and location. As implied by their names, a size dimension shows the size of an object or parts of an object and a location dimension is used to describe the location of features. Examples of both size and location dimensions are shown in figure 3-40. While on the subject of dimensions, it should be noted that large objects are seldom drawn to their true size. Instead, the engineer or draftsman reduces the size of the object “to scale.” For example, when drawing a 40-foot tower, the drawing may be prepared using a scale of $1/2" = 1'-0"$. In this case, the height of the tower, on paper, is 20 inches. The scale used to prepare working drawings is always noted on the drawing. It may be a fractional scale, such as discussed here, or a graphic scale, such as the one shown in figure 3-40. Often both numerical and graphic scales are usually shown on construction drawings.



FENI POLYTECHNIC INSTITUTE, FENI

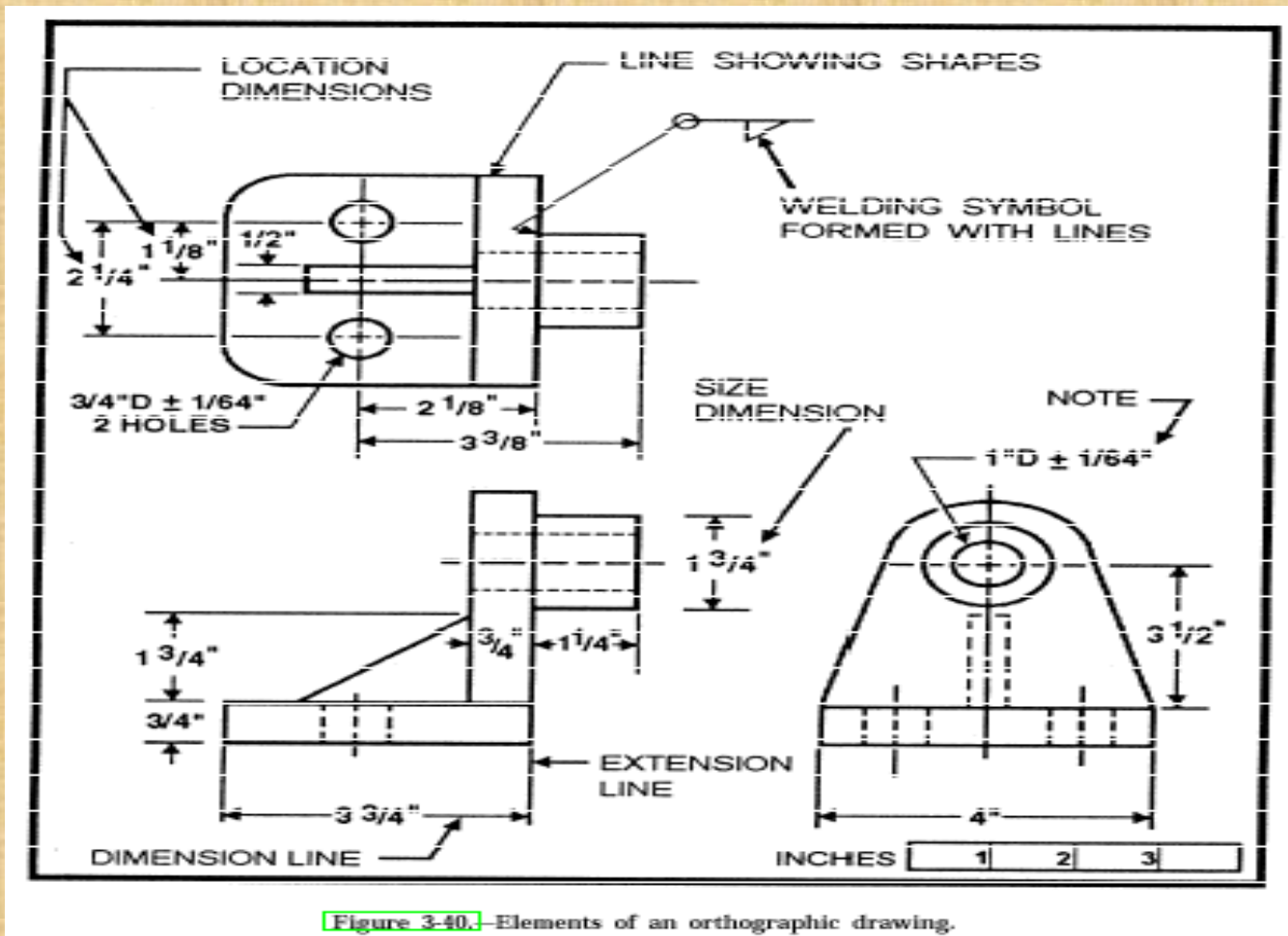



FENI POLYTECHNIC INSTITUTE, FENI



- **Notes** Drawing notes are used for different purposes and are either general or specific in nature. One example of how notes are used are the two notes shown in figure 3-40 that give the inside diameters of the holes. As you can see, these notes are used for size dimensioning. They are specific notes in that, by using a leader line, each note is referred to a specific hole or set of holes. A general note is used to provide additional information that does not apply to any one particular part or feature of the drawing. For example, the drawing shown in figure 3-40 could contain a general note saying: “All holes shall be reamed using a tolerance of $\pm 1/64$ inch.”

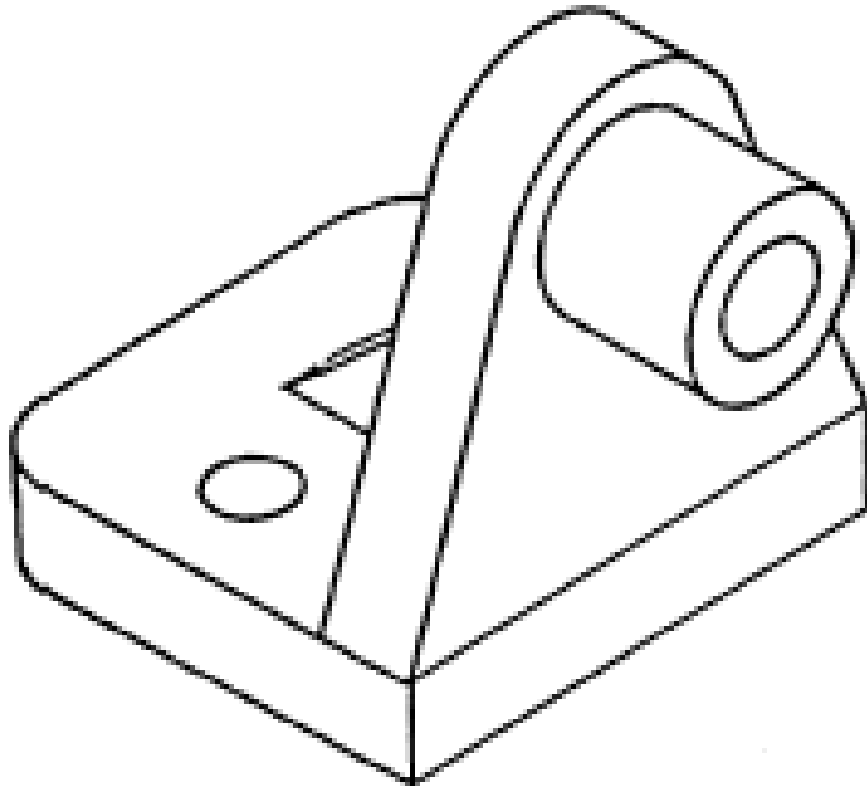

Figure 3-41.—Pictorial drawing of a steel part.

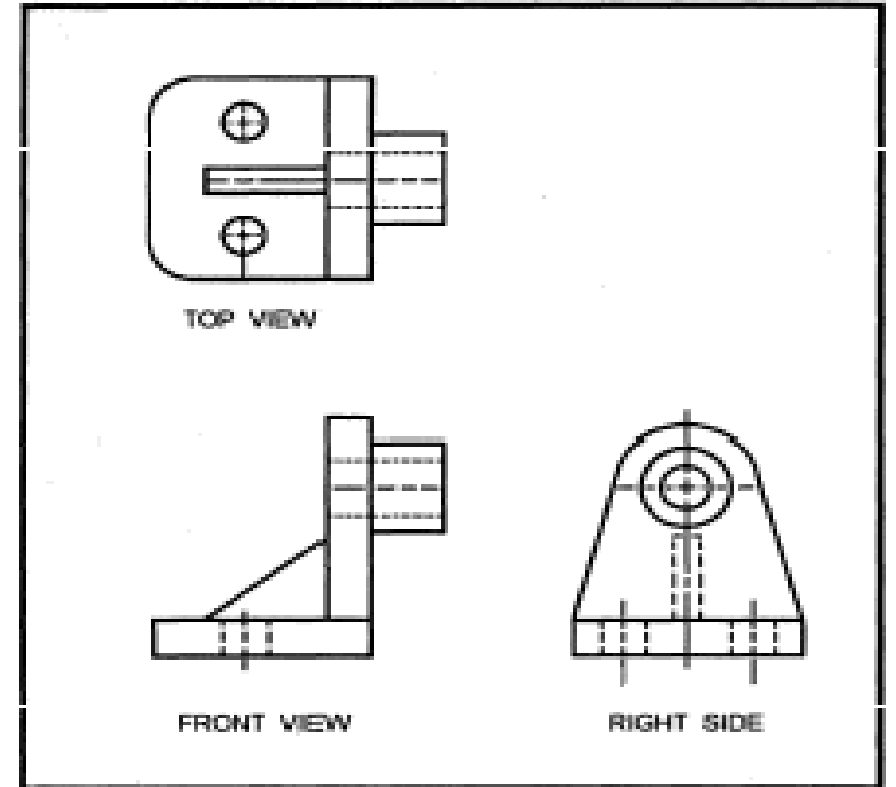

Figure 3-42.—Three-view orthographic drawing of the steel part shown in **figure 3-41**.



FENI POLYTECHNIC INSTITUTE, FENI



- **Handling and Care of Drawings** Special care should be exercised in the handling of drawings. When they are not being used, keep them on a rack or in another assigned place of storage. Drawings are valuable, and they may be difficult or impossible to replace if they are lost or damaged.



- **Types of Lines** The basis of any drawing is a line. The use of a right type of line results in a correct drawing. The Bureau of Indian Standards has prescribed the types of lines in its code IS-10714-1983 to be used for making a general engineering drawing. Table 1 shows the types and thickness of lines used for various purposes. Each line is used for a definite purpose and it should not be used for anything else. (Refer Fig. 1). The various types of lines and their uses are described below: (a) **Outlines (A)**. Lines drawn to represent visible edges and surface boundaries of objects are called outlines or principal lines. These are continuous thick lines. (b) **Margin Lines (A)**. These are continuous thick lines along which the prints are trimmed.













- (c) **Dimension Lines (B).** These lines are continuous thin lines. These are terminated at the outer ends by pointed arrowheads touching the outlines, extension lines or centre lines. (d) **Extension or Projection Lines (B).** These lines are also continuous thin lines. They extend by about 3 mm beyond the dimension lines. (e) **Construction Lines (B).** These lines are drawn for constructing figures. These are shown in geometrical drawings only. These are continuous thin light lines. (f) **Hatching or Section Lines (B).** These lines are drawn to make the section evident. These are continuous thin lines and are drawn generally at an angle of 45° to the main outline of the section. These are uniformly spaced about 1 mm to 2 mm apart.



FENI POLYTECHNIC INSTITUTE, FENI



- Table No. 1 Types of Lines

Line	Description	General Application
A	 Continuous thick	A1 Visible outlines. A2 Visible edges.
B	 Continuous thin (straight or curved)	B1 Imaginary lines of intersection. B2 Dimension lines. B3 Projection lines. B4 Leader lines. B5 Hatching lines. B6 Outlines of revolved sections in place. B7 Short centre lines
C	 Continuous thin free hand	C1 Limits of partial or interrupted views and sections, if the limit is not a chain thin.
D	 Continuous thin (straight) with zigzags	D1 Long break line
E	 Dashed thick	E1 Hidden outlines. E2 Hidden edges.
F	 Dashed thin	F1 Hidden outlines. F2 Hidden edges.
G	 Chain thin	G1 Center lines. G2 Lines of symmetry. G3 Trajectories
H	 Chain thin, thick at ends and changes of direction	H1 Cutting planes.
J	 Chain thick	J1 Indication of lines or surfaces to which a special requirement applies
K	 Chain thin double dashed	K1 Outlines of adjacent parts. K1 Alternative or extreme position of movable parts. K3 Centroidal lines. K4 Initial outlines prior to forming K5 Parts situated in front of the cutting plane



- (g) **Leader or Pointer Lines (B)**. Leader line is drawn to connect a note with the feature to which it applies. It is a continuous thin line. (h) **Border Lines (B)**. Perfectly rectangular working space is determined by drawing the border lines. These are continuous thin lines. (j) **Short-Break Lines (C)**. These lines are continuous, thin and wavy. These are drawn freehand and are used to show a short break, or irregular boundaries. (k) **Long-Break Lines (D)**. These lines are thin ruled lines with short zigzags within them. These are drawn to show long breaks.



- (I) **Hidden or Dotted Lines (E or F).** Interior or hidden edges and surfaces are shown by hidden lines. These are also called dashed lines or dotted lines. These are of medium thickness and made up of short dashes of approximately equal lengths of about 2 mm spaced at equal distances of about 1 mm. When a hidden line meets or intersects another hidden line or an outline, their point of intersection or meeting should be clearly shown. (m)



- **Centre Lines (G).** Centre lines are drawn to indicate the axes of cylindrical, conical or spherical objects or details, and also to show the centers of circles and arcs. These are thin, long, chain lines composed of alternately long and short dashes spaced approximately 1 mm apart. The longer dashes are about 6 to 8 times the short dashes which are about 1.5 mm long. Centre lines should extend for a short distance beyond the outlines to which these refer. For the purpose of dimensioning or to correlate the views these may be extended as required. The point of intersection between two centre lines must always be indicated. Locus lines, extreme positions of movable parts and pitch circles are also shown by this type of line. (n).



- **Cutting-Plane Lines (H)**. The location of a cutting plane is shown by this line. It is a long, thin chain line, thick at ends only. (o) **Chain Thick (J)**. These lines are used to indicate special treatment on the surface. (p) **Chain Thick Double Dashed (K)**. This chain thin double dashed is used for outline for adjacent parts, alternative and extreme, position of movable part, centroidal lines, initial outlines prior to forming and part suited in front of the cutting plane



FENI POLYTECHNIC INSTITUTE, FENI

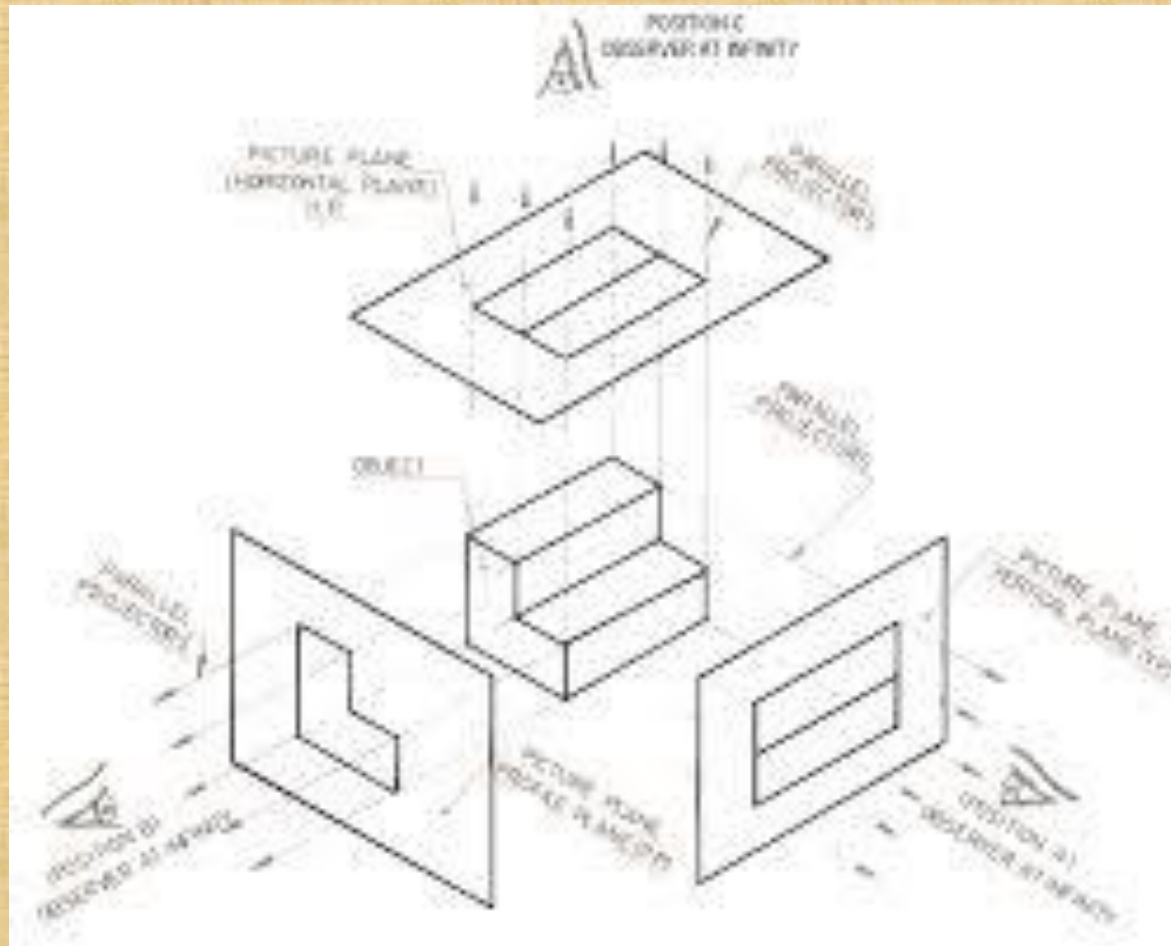



- **Introduction**

- One of the best ways to communicate one's ideas is through some form of picture or drawing. This is especially true for the engineer. The purpose of this guide is to give you the basics of engineering sketching and drawing. We will treat "sketching" and "drawing" as one. "Sketching" generally means freehand drawing. "Drawing" usually means using drawing instruments, from compasses to computers to bring precision to the drawings. This is just an introduction. Don't worry about understanding every detail right now - just get a general feel for the language of graphics. We hope you like the object in Figure 1, because you'll be seeing a lot of it. Before we get started on any technical drawings, let's get a good look at this strange block from several angles.



Figure 1 - A Machined Block

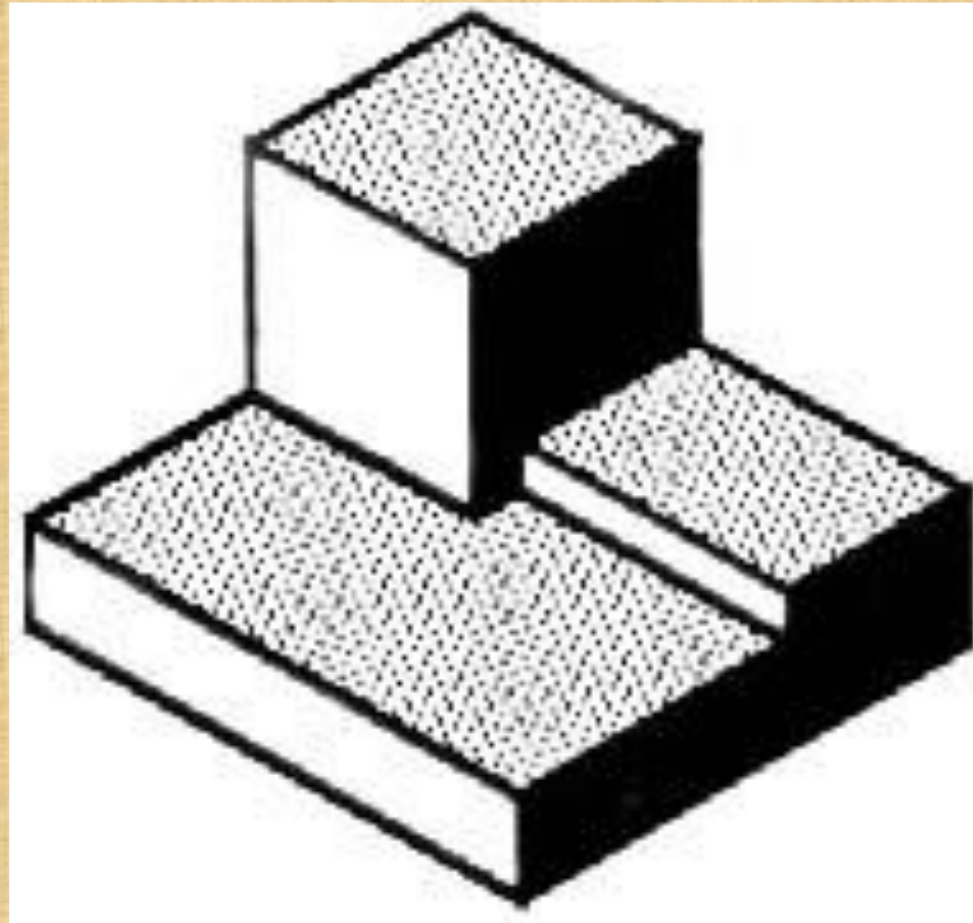



• Isometric Drawing

- The representation of the object in figure 2 is called an isometric drawing. This is one of a family of three-dimensional views called pictorial drawings. In an isometric drawing, the object's vertical lines are drawn vertically, and the horizontal lines in the width and depth planes are shown at 30 degrees to the horizontal. When drawn under these guidelines, the lines parallel to these three axes are at their true (scale) lengths. Lines that are not parallel to these axes will not be of their true length. Any engineering drawing should show everything: a complete understanding of the object should be possible from the drawing. If the isometric drawing can show all details and all dimensions on one drawing, it is ideal. One can pack a great deal of information into an isometric drawing. However, if the object in figure 2 had a hole on the back side, it would not be visible using a single isometric drawing. In order to get a more complete view of the object, an orthographic projection may be used.



- **Figure 2 - An Isometric Drawing**

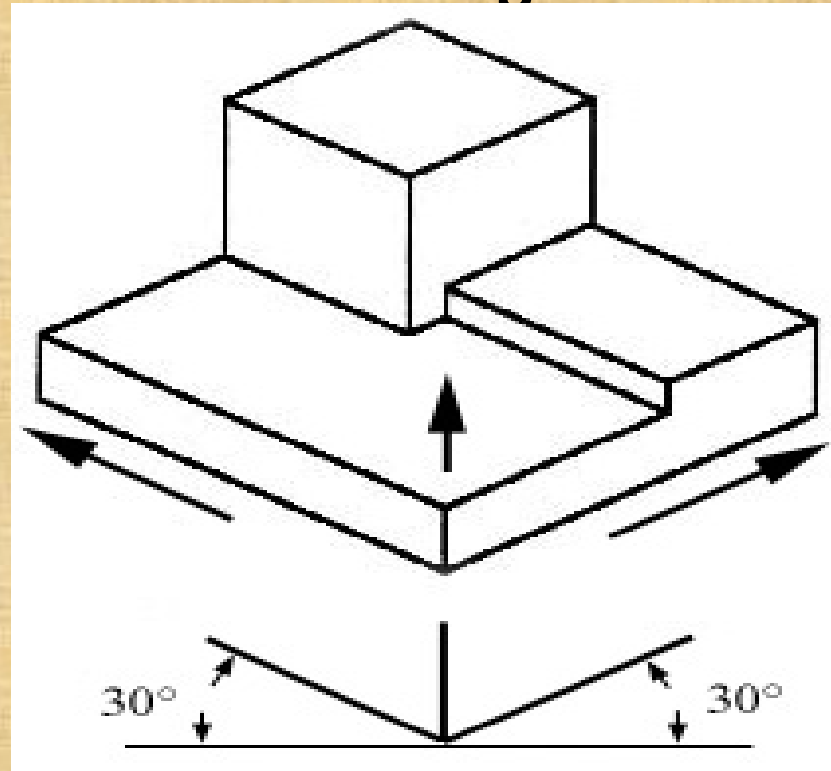



- **Orthographic or Multi view Drawing**
- Imagine that you have an object suspended by transparent threads inside a glass box, as in figure 3.

Figure 3 - The block suspended in a glass box

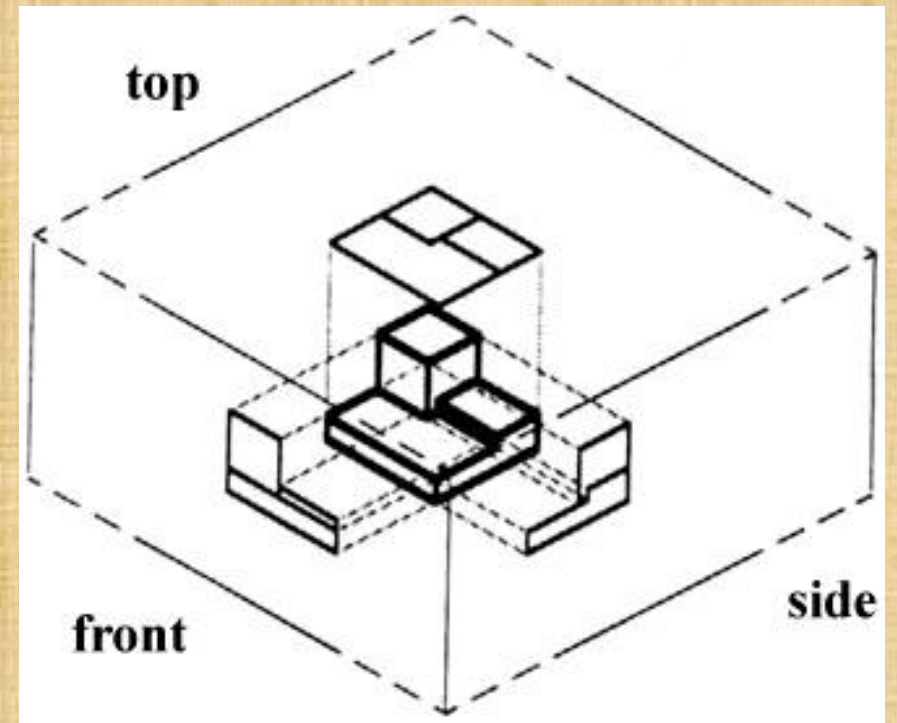
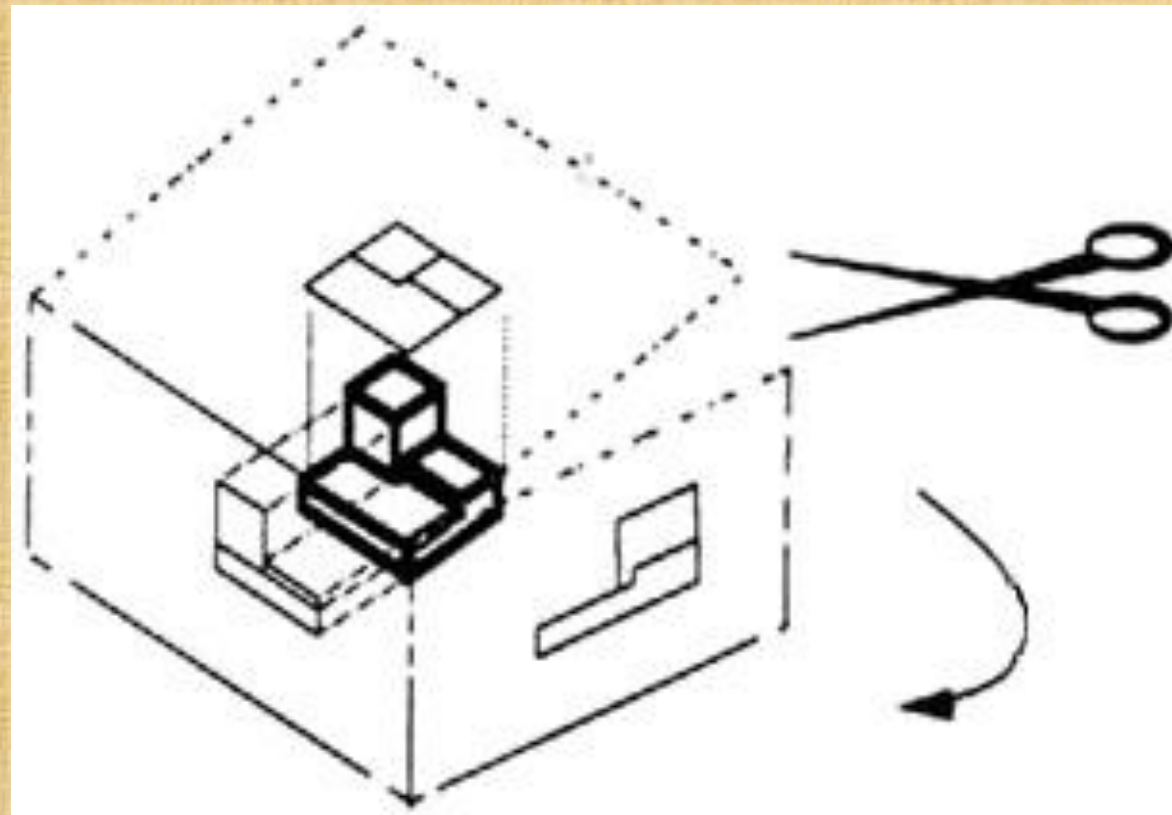

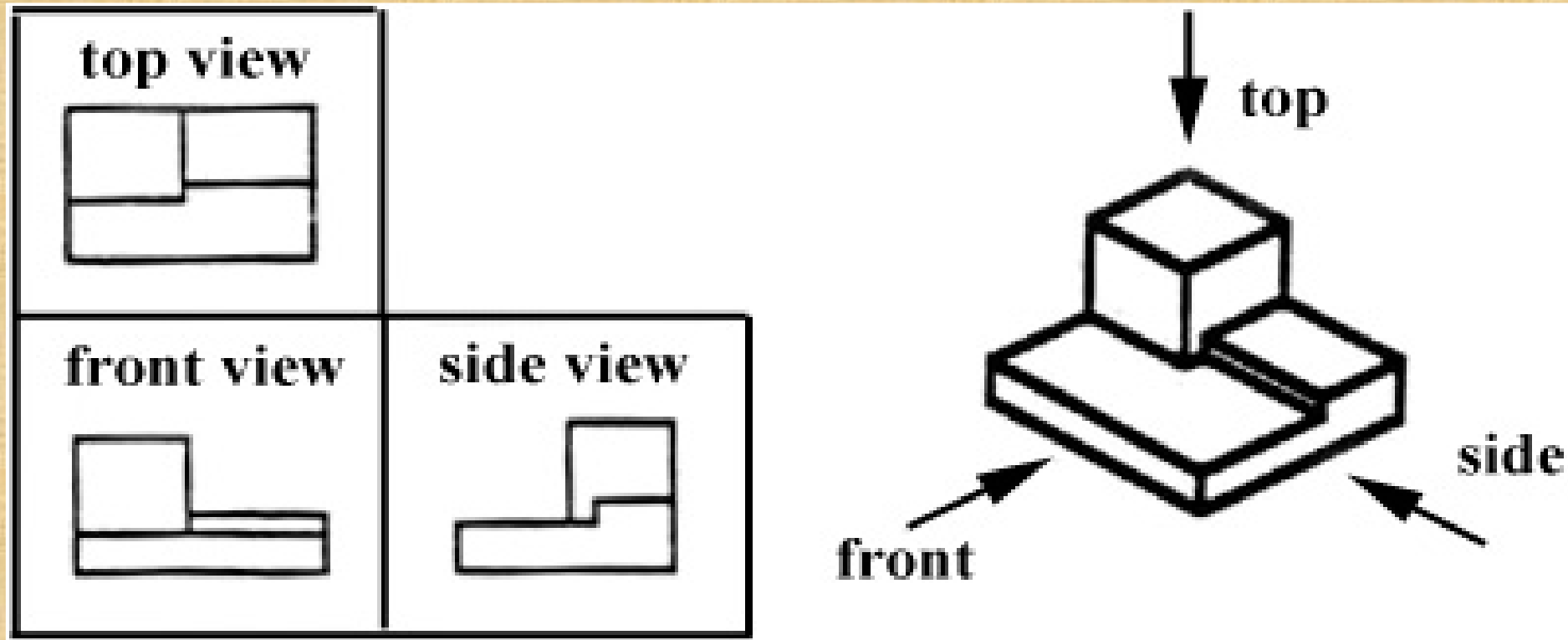

Figure 4 - The creation of an orthographic multiview drawing





- Figure 5 shows how the three views appear on a piece of paper after unfolding the box. **Figure 5 - A multiview drawing and its explanation**





- Which views should one choose for a multiview drawing? The views that reveal every detail about the object. Three views are not always necessary; we need only as many views as are required to describe the object fully. For example, some objects need only two views, while others need four. The circular object in figure 6 requires only two views.

Figure 6 - An object needing only two orthogonal views

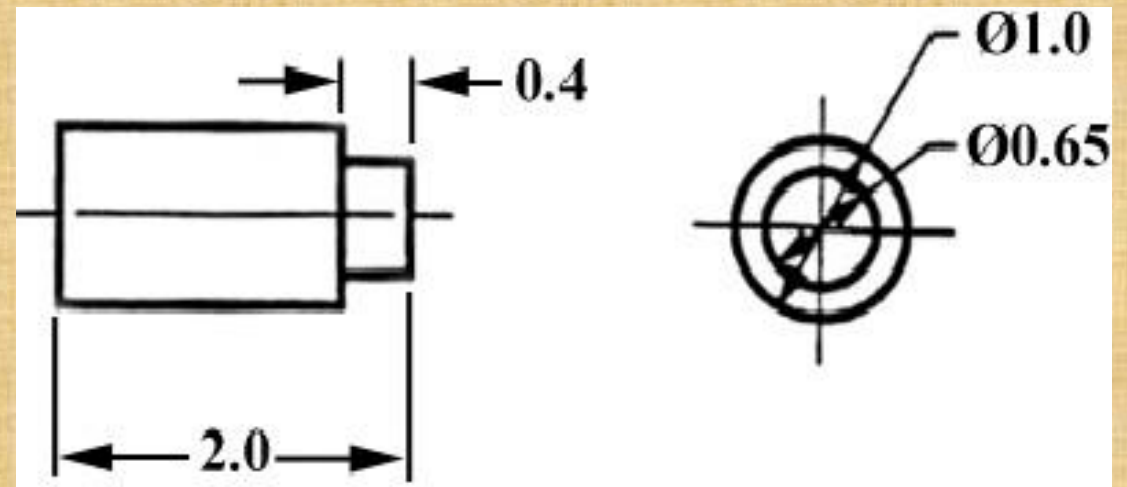



- Dimensioning
- Figure 7 - An isometric view with dimensions

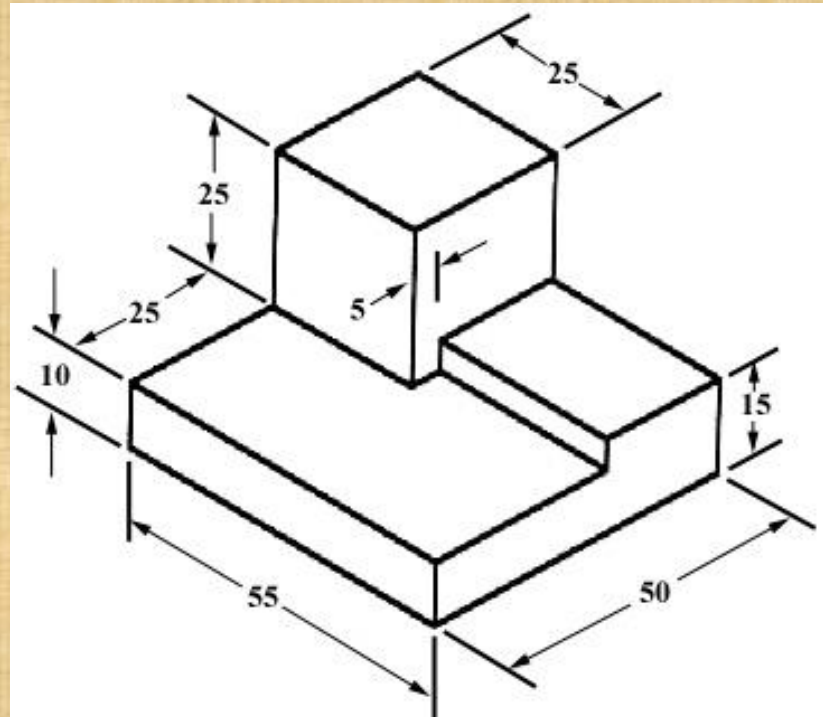



FENI POLYTECHNIC INSTITUTE, FENI



- We have "dimensioned" the object in the isometric drawing in figure 7. As a general guideline to dimensioning, try to think that you would make an object and dimension it in the most useful way. Put in exactly as many dimensions as are necessary for the craftsman to make it -no more, no less. Do not put in redundant dimensions. Not only will these clutter the drawing, but if "tolerances" or accuracy levels have been included, the redundant dimensions often lead to conflicts when the tolerance allowances can be added in different ways. Repeatedly measuring from one point to another will lead to inaccuracies. It is often better to measure from one end to various points. This gives the dimensions a reference standard. It is helpful to choose the placement of the dimension in the order in which a machinist would create the part. This convention may take some experience.



- **Sectioning**
- There are many times when the interior details of an object cannot be seen from the outside (figure 8). **Figure 8 - An isometric drawing that does not show all details**

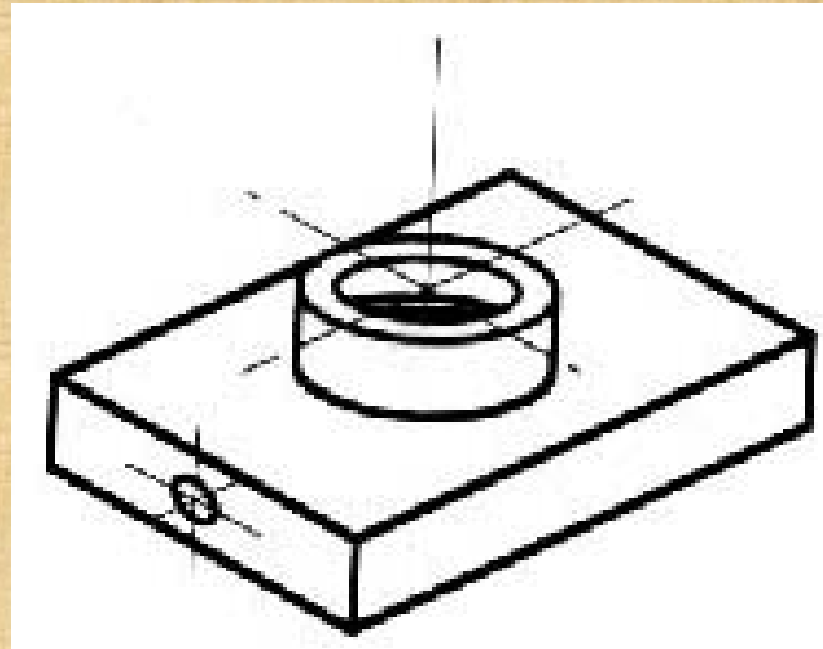



- We can get around this by pretending to cut the object on a plane and showing the "sectional view". The sectional view is applicable to objects like engine blocks, where the interior details are intricate and would be very difficult to understand through the use of "hidden" lines (hidden lines are, by convention, dotted) on an orthographic or isometric drawing. Imagine slicing the object in the middle
- (figure 9):

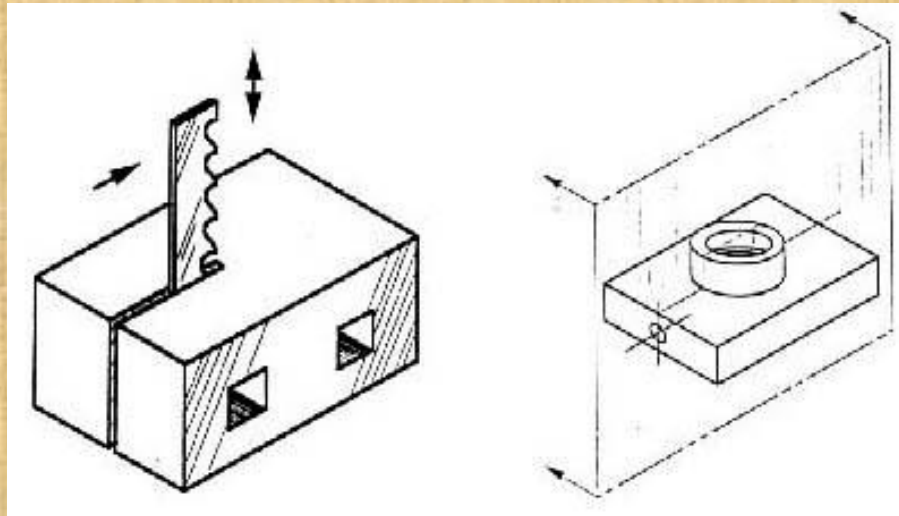



- **Figure 10 - Sectioning the object in figure 8**

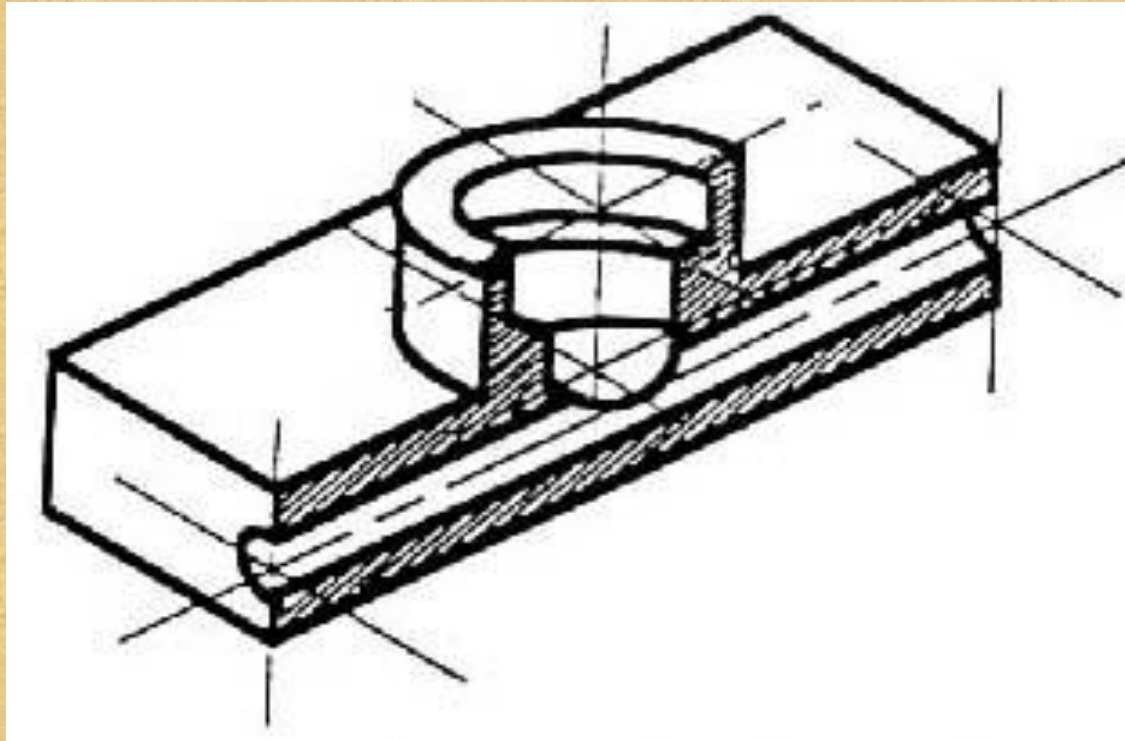

- **Figure 11 - Sectioned isometric and orthogonal views**

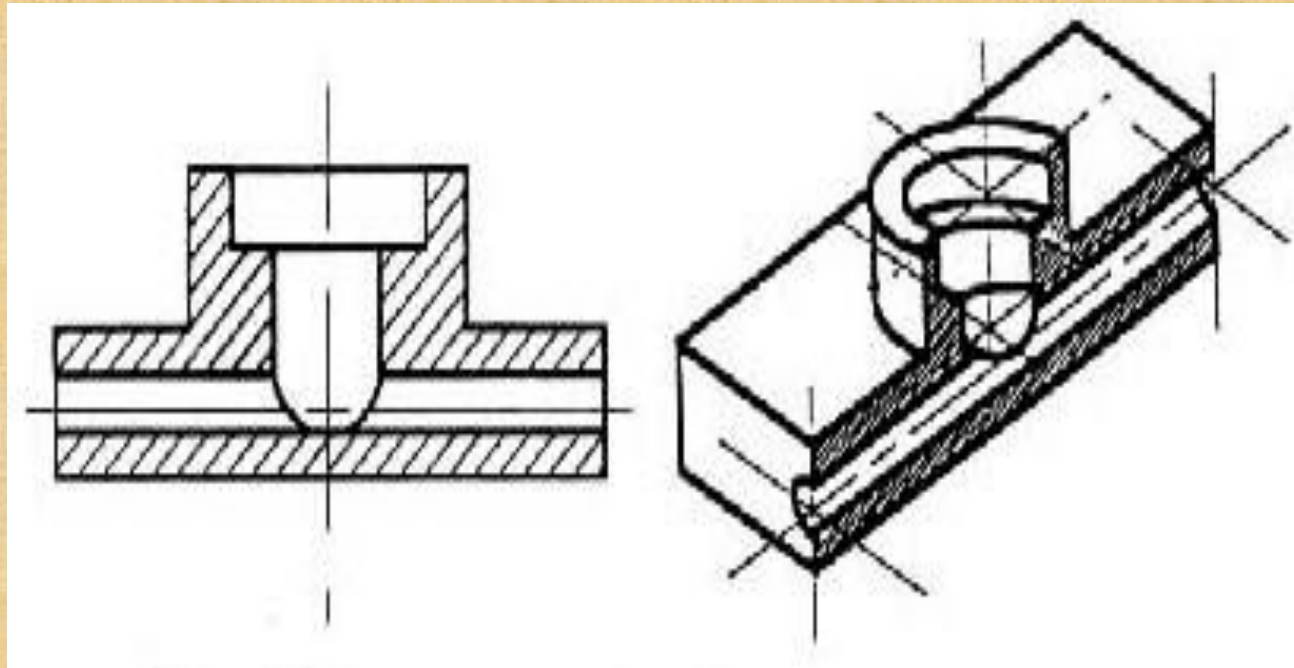

The cross-section looks like figure 11 when it is viewed from straight ahead.



- **Drawing Tools**
- To prepare a drawing, one can use manual drafting instruments (figure 12) or computer-aided drafting or design, or CAD. The basic drawing standards and conventions are the same regardless of what design tool you use to make the drawings. In learning drafting, we will approach it from the perspective of manual drafting. If the drawing is made without either instruments or CAD, it is called a freehand sketch.

- **Figure 12 - Drawing Tools**

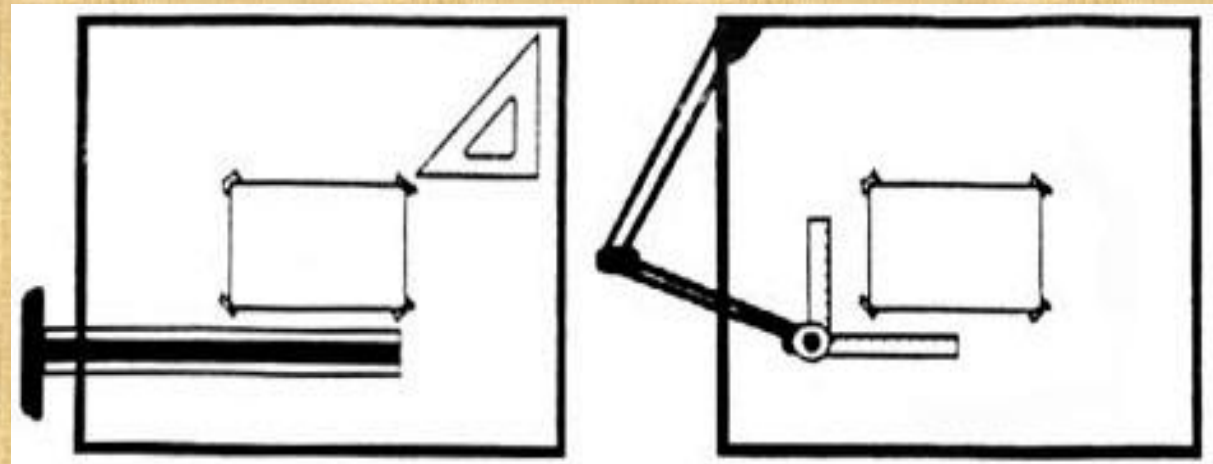



FENI POLYTECHNIC INSTITUTE, FENI

